

An Unbalanced Mute Circuit for Audio Mixing Channels

This application note describes a dual channel unbalanced analog audio mute switch, for use in audio console mute circuits. The SSM-2402 dual audio switch, when used in the virtual ground configuration, truly enhances any audio mute design. The application, as shown in Figure 1, incorporates unbalanced stereo input buffers, dual stereo electronic virtual ground switches (with simplified control circuit), and virtual ground summing amplifiers.

THE AUDIO SWITCH AS IMPLEMENTED

The design utilizes the SSM-2402 (U_1 and U_2) dual audio switch in a virtual ground switching configuration. This method of operation improves linearity over a wide dynamic range. The SSM-2402 utilizes JFET switching, with internal wide bandwidth integrated amplifiers applied in a unique configuration. The result is low transient intermodulation distortion, low THD, and low IMD, while essentially eliminating all audio switching

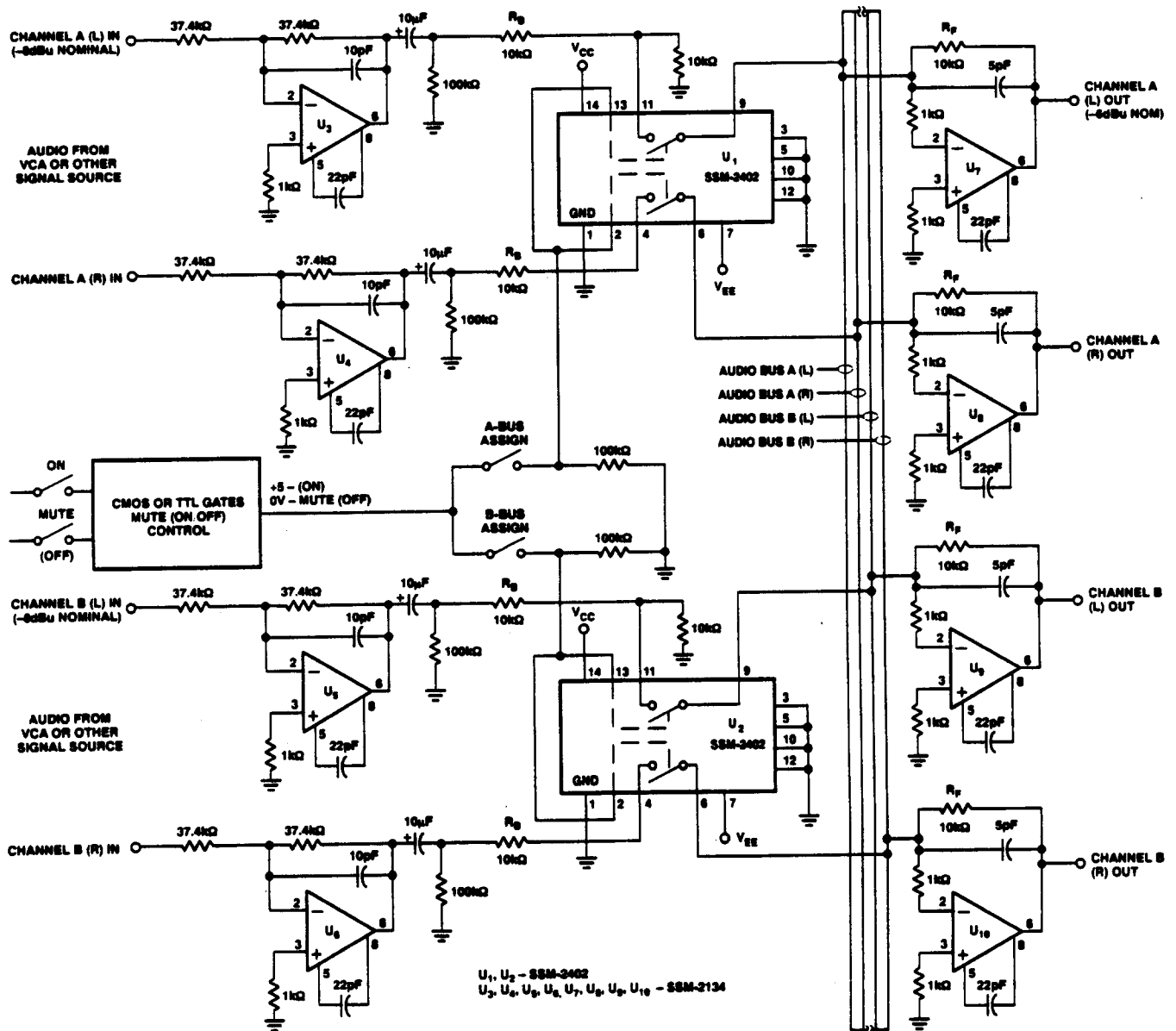

U_1, U_2 - SSM-2402
 $U_3, U_4, U_5, U_6, U_7, U_8, U_9, U_{10}$ - SSM-2134

FIGURE 1: Audio Mixer Channel Mute (On/Off) Circuit (Unbalanced Design with Virtual Ground Switching)

transients. The SSM-2402 switch closed (ON) resistance is typically 60Ω in series with R_B ($10k\Omega$). As shown in this mixing system, the tolerance of the 60Ω contributes to less channel imbalance than the 1% resistor tolerance, thus eliminating the need for level trim adjustments.

The SSM-2402 employs a "T" switching configuration that yields superior ON-OFF signal isolation. In the OFF state, the "T" configuration of the SSM-2402 virtually eliminates leakage of the input signal (down more than 100dB at 1kHz with guard pins 3, 5, 10 and 12 grounded) onto the mixing bus(es). The part also features a 7ms ramped turn ON and 4ms ramped turn OFF, for transient free audio switching even with signal applied. The switch also operates with a break-before-make switching sequence. These properties are significant when many remotely controlled electronic switches are connected in series and controlled by a single device, as in large audio systems managed by an automation computer.

CONTROL INTERFACE

In this application note, the bus assignment (selection) switches are shown functionally for clarity. The control ports of the SSM-2402 can easily be interfaced to conventional 5V TTL or CMOS logic control circuits. $+5V_{DC}$ (logic high) closes the switch (ON), and $0V_{DC}$ (logic low) opens the switch (OFF). The common interface levels improve the reliability and serviceability of any products it's designed into. Diverse logic gate control designs or computer controlled schemes can easily be implemented.

DRIVE REQUIREMENTS - THE INPUT CIRCUIT

The application employs two SSM-2402 dual audio switches in a four-bus configuration (two stereo buses) driven by U_3 , U_4 and U_5 , U_6 bipolar amplifiers. The buffer amplifiers are signal inverting, with their gain set to 0dB ($A_v = 1$). The input amplifiers also serve as source signal level clippers that prevent the input signal from exceeding the input range of the switches, thus preventing the switches from passing a distorted signal when overdriven in the open (OFF) state. A nominal input drive level of $-10dBu$ is applied to the switch and will maximize the signal-to-noise ratio, and optimize headroom. The output of U_3 , U_4 , U_5 , and U_6 are AC coupled to further minimize the switching transient noise caused by signal path DC voltages from previous origins.

The virtual ground mixing buses are current driven by R_B ($10.0k\Omega$) resistors. Once again, this is a compromise value that can be changed to accommodate the extent of the mixing bus implemented. A greater number of input mixing channels will warrant a lower bus drive current. Although other values can be used, the resistance values of R_B and R_F should be the same.

As shown ($\pm 18V_{DC}$ power) R_B will apply approximately 1.7mA peak current to the mixing bus. This is well within SSM-2402 switching capabilities, as well as the SSM-2134 drive capabilities. The signal current is low enough to keep return ground currents low enough to prevent crosstalk resulting from the mechanical wiring constraints. Returning ground currents independently to the noninverting input of the summing amplifier is advised.

THE OUTPUT SUMMING AMPLIFIER

The design utilizes the SSM-2134, the PMI version of the popular NE5534 bipolar operational amplifier. The circuit features a significant reduction in summing amplifier noise, a decrease in temperature and bus impedance effects on the static output voltage as a result of using a bipolar amplifier. This design also balances the input circuit reflected source impedance of the bipolar IC amplifier, alleviating the unity-gain instability and eliminating the unbalanced input topology for inverting summing designs that could cause output offset.

The SSM-2134 has a noise voltage of $2.8nV/\sqrt{Hz}$, thus the noise floor is reduced by 3 to 10dB. Additionally, frequency and phase response performance have been improved. Only minimal compensation is required in the feedback loop of the SSM-2134 to maintain unconditional stability. The slew rate remains greater than $10V/\mu s$, with bandwidth exceeding 50kHz.

SUMMARY

The design application shown in Figure 1 is signal noninverting, and utilizes a minimum number of noise generating elements. The circuit configuration produces linear signal mixing at the virtual ground summing node ($e_S = 0V_{AC}$); therefore, no reflected interaction occurs between the input sources. The signal input to any output frequency response is typically 10Hz to 50kHz, $\pm 0.5dB$. Total harmonic distortion plus noise will measure less than 0.01%, from 20Hz to 20kHz. SMPTE intermodulation distortion is less than 0.02%. With prudent printed circuit board design, a greater than 100dB mute isolation @ 1kHz can be obtained.

The application shown employs $\pm 18V_{DC}$ power supplies to produce a $+24dBu$ audio output clip level. All SSM components will operate with equal reliability at $\pm 20V_{DC}$, producing approximately a 1dB increase in clip level. If the extra headroom is necessary, a $\pm 20V_{DC}$ power supply voltage is encouraged. The noise increase will be indiscernible, even in large mixing systems.